

M. RICE.  
Cutting and Boring Attachment for Lathe.

No. 201,948.

Patented April 2, 1878.

Fig. 2.

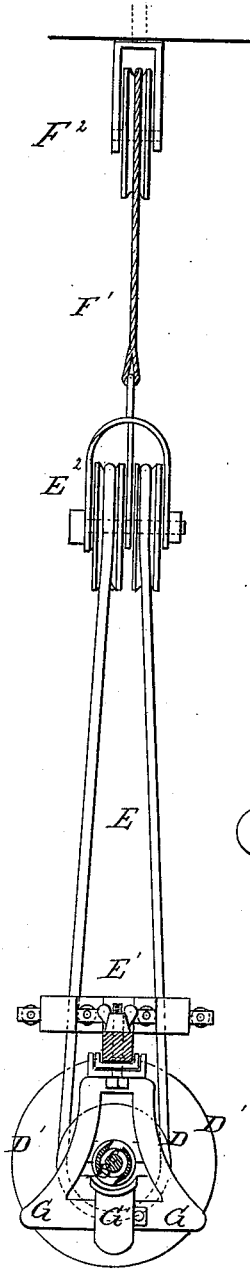

Fig. 1.

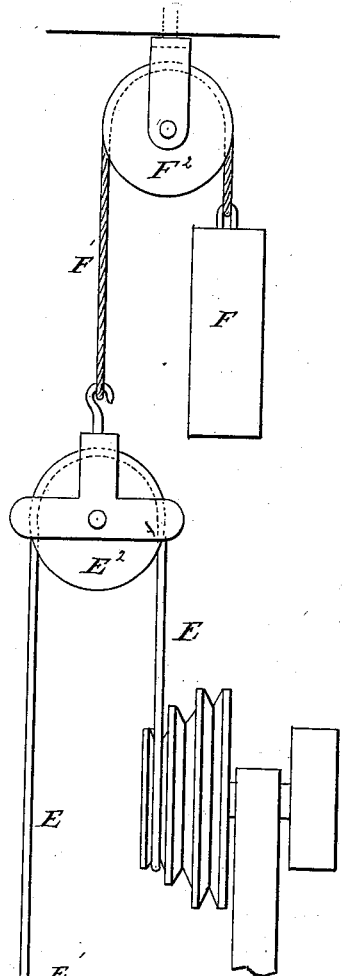
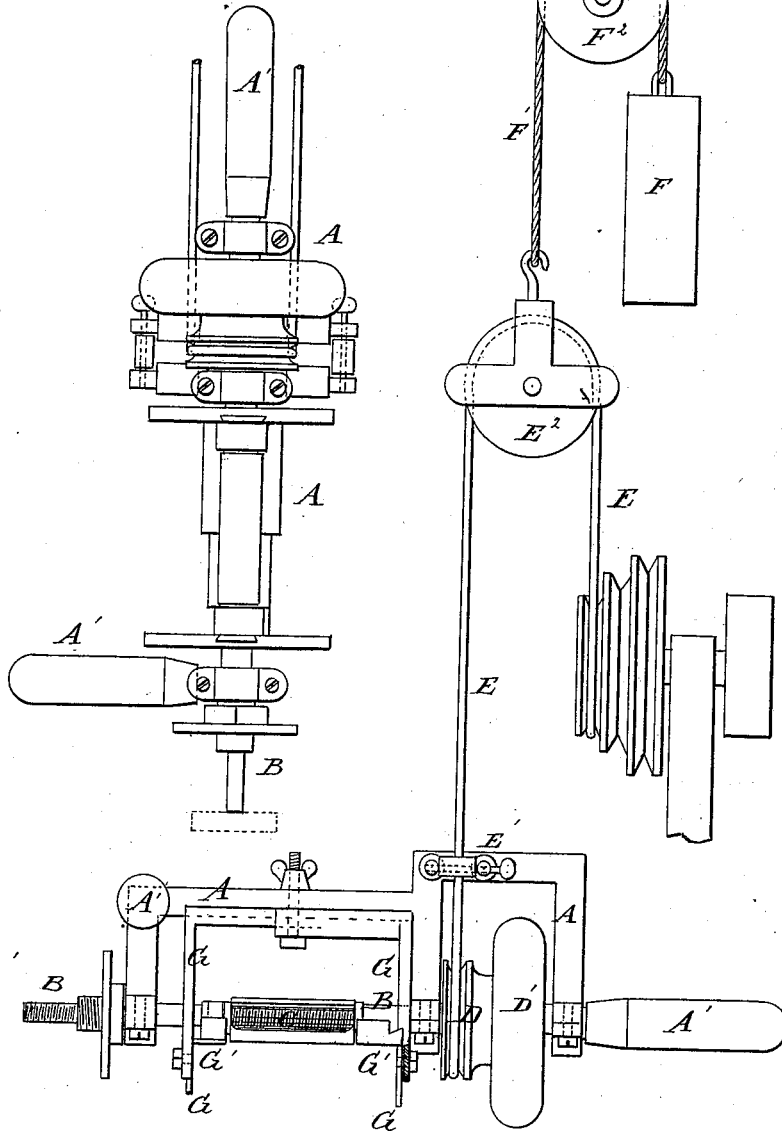

Fig. 3.



WITNESSES:

*Chas. N. Rice*  
*C. Sedgwick*

INVENTOR:

*M. Rice*

BY

*Munnis & Co.*

ATTORNEYS.

# UNITED STATES PATENT OFFICE.

MATHEW RICE, OF AUGUSTA, GEORGIA.

## IMPROVEMENT IN CUTTING AND BORING ATTACHMENTS FOR LATHES.

Specification forming part of Letters Patent No. **201,948**, dated April 2, 1878; application filed January 5, 1878.

*To all whom it may concern:*

Be it known that I, MATHEW RICE, of Augusta, in the county of Richmond and State of Georgia, have invented a new and Improved Cutting and Boring Attachment to Lathes, of which the following is a specification:

In the accompanying drawings, Figure 1 represents a side elevation of my improved cutting and boring attachment to lathes. Fig. 2 is an end view, partly in vertical transverse section; and Fig. 3, a side view of the attachment, arranged in vertical position for boring and other purposes.

Similar letters of reference indicate corresponding parts.

My invention relates to a hand-machine for shaping, molding, &c., and will first be described in connection with the drawing, and then pointed out in the claim.

A represents the supporting-frame, in three bearings of which turns the shaft B, the said frame being in two sections, of which the longer is provided with the planing-knives, and the shorter with the balance-wheel D' and V-pulley D. The shaft B extends beyond both sections of frame, and is provided with a socket for the reception of interchangeable cutting-tools at both ends, for the purpose of attaching emery-wheels.

The face-plate (shown in Fig. 3 of the drawing) receives the sand-paper for polishing wood or iron, and moves upon a threaded shaft, to which it is held by a jam-nut. The frame is held to the work by means of handles A'.

The band E passes over pulley D and between guide-rolls E, over the suspended pulley E<sup>2</sup>, and over the lathe-pulley. The entire attachment is balanced by a weight, F, attached to a cord, F<sup>1</sup>, passing over a ceiling-pulley, F<sup>2</sup>, to the pulley E<sup>2</sup>, to which it is secured by a swivel-hook that turns with the belt in any direction. This enables the device to be carried to the work with great facility without cutting or injuring the belt.

G' G' are adjustable guides on the shaft B, and having flanges that form slide-bearings, and are provided with bolt-slots. These guides lap the supporting-frame on the inside, and are held at the desired adjustment by the bolt and the nut thereon. They are also provided with the vertical detachable and adjustable gages G G, that slide on the said guides to regulate the depth of cut, while the guides direct and steady the device to any desired templet or design.

Having thus described all that is necessary to a full understanding of my invention, what I claim as new is—

The lathe attachment, consisting of the supporting-frame A, having handle A', the shaft B, the pulley D, balance-wheel D', adjustable gages G, and guides G', as shown and described.

MATHEW RICE.

Witnesses:

T. M. PREVAL,  
A. J. DAVIS.